

1-095 Quarter-Turn Pr20.1 L18

Tool or hand operable, Optional pre-assembly



Product Notes:

- RH and LH application
- Pre-assembly by DIRAK is advisable
- Pre-assembled Quarter-Turn can be installed in cutout
- Double insulated

Material:

- Housing, insert and cam: PA, Black

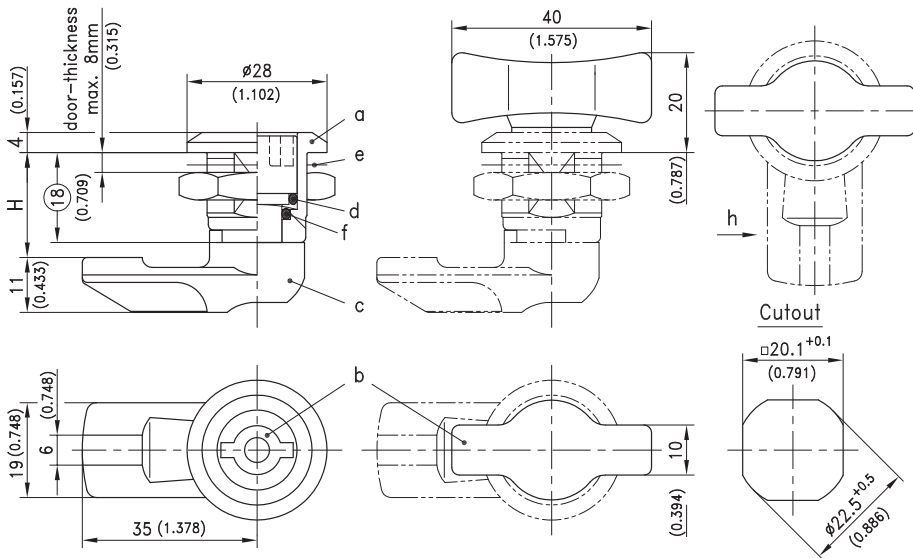
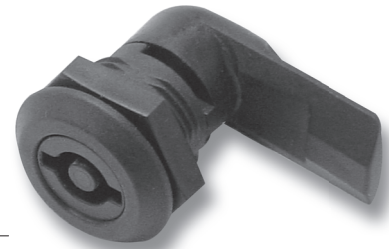

a) Housing	Part No.	See Page
PA with nut PA (black)	200-9077	
PA with nut steel (zinc plated)	200-9003	
PA with nut (stainless steel)	200-9044	
b) Insert with wave washer and screw		
Square 7mm	200-9155	
Square 8mm	200-9156	
Triangular 8mm	200-9158	
Double bit 3mm pin	200-9159	
Double bit 5mm pin	200-9160	
Slotted 2x4mm deep	200-9161	
Wing knob	200-9173	
Slotted recessed coinproof	200-9186	
Crescent Czech	200-9184	
c) Cam (further cams on request)	H mm / inch	
	18 / 0.709	200-5318
	20 / 0.787	200-5320
	22 / 0.866	200-5322
	25 / 0.984	200-5325
	28 / 1.102	200-5328
c1) Cams, steel zinc plated		01.101
Optional:		
Water and dust tight according to IP65 by:		
O-ring 12x2mm	200-1001	
e) Flat external seal	200-0901	
Water and dust tight according to IP67 by additional:		
d) O-ring 10x2mm	200-1002	
f) Assembling of cam	200-0001	
Assembling of cam, with O-ring	200-0002	
g) Assembling cam 90° to handle without O-ring	200-0019	
Assembling cam 90° to handle with O-ring	200-0033	